

12	GESEH. APP.
11	GEPR. CHECK.
10	BEARB. DRAWN
9	DATUM DATE
8	ÄNDERUNG DESCRIPTION OF CHANGE
7	AE. -M. NO. CH. -NO.

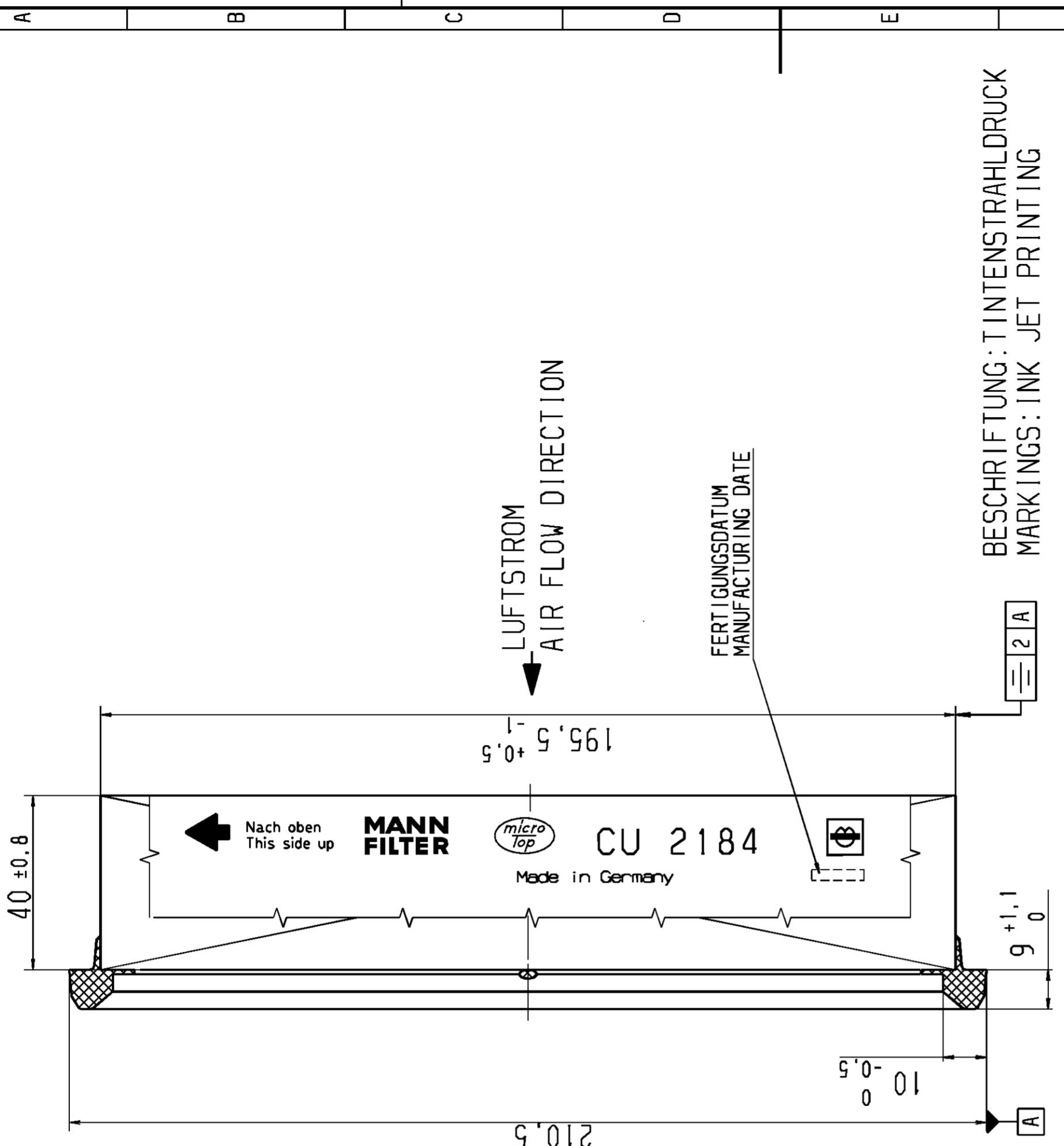

BESCHRIFTUNG: TINTENSTRAHLDRUCK
MARKINGS: INK JET PRINTING

Elsässer Industrietechnik GmbH	
ISO 128	ANGEBOTSZEICHNUNG CUSTOMER DRAWING
ISO 128	SCHUTZVERMERK D IN 34 BEACHTEN / PROTECTION MARK ACCORDING TO DIN 34
MASS-STAB SCALE	THE COPYING, DISTRIBUTION AND UTILIZATION OF THIS DOCUMENT AS WELL AS THE COMMUNICATION OF ITS CONTENTS TO OTHERS WITHOUT EXPRESSED AUTHORIZATION IS PROHIBITED. OFFENDERS WILL BE HELD LIABLE FOR THE PAYMENT OF DAMAGES. ALL RIGHTS RESERVED IN THE EVENT OF THE GRANT OF A PATENT, UTILITY MODEL OR ORNAMENTAL DESIGN REGISTRATION.
1:1	
ABT./DEPT. AE-EK	DATUM DATE
21.12.98	GOMBALA
30.08.99	SOMMER
30.08.99	LUKA
BENENNUNG / NAME	
MANN	
IR-FILTERELEMENT CABIN/FILTER ELEMENT	
ZEICHNUNGS-NR. DRAWING-NO.	
CU 2184	
FILTERTYPER MANN+HUMMEL GMBH	
D-71631 LUDWIGSBURG	
44 084 54 306	
ERSATZ FUER / SUBSTITUTE FOR	
A2	

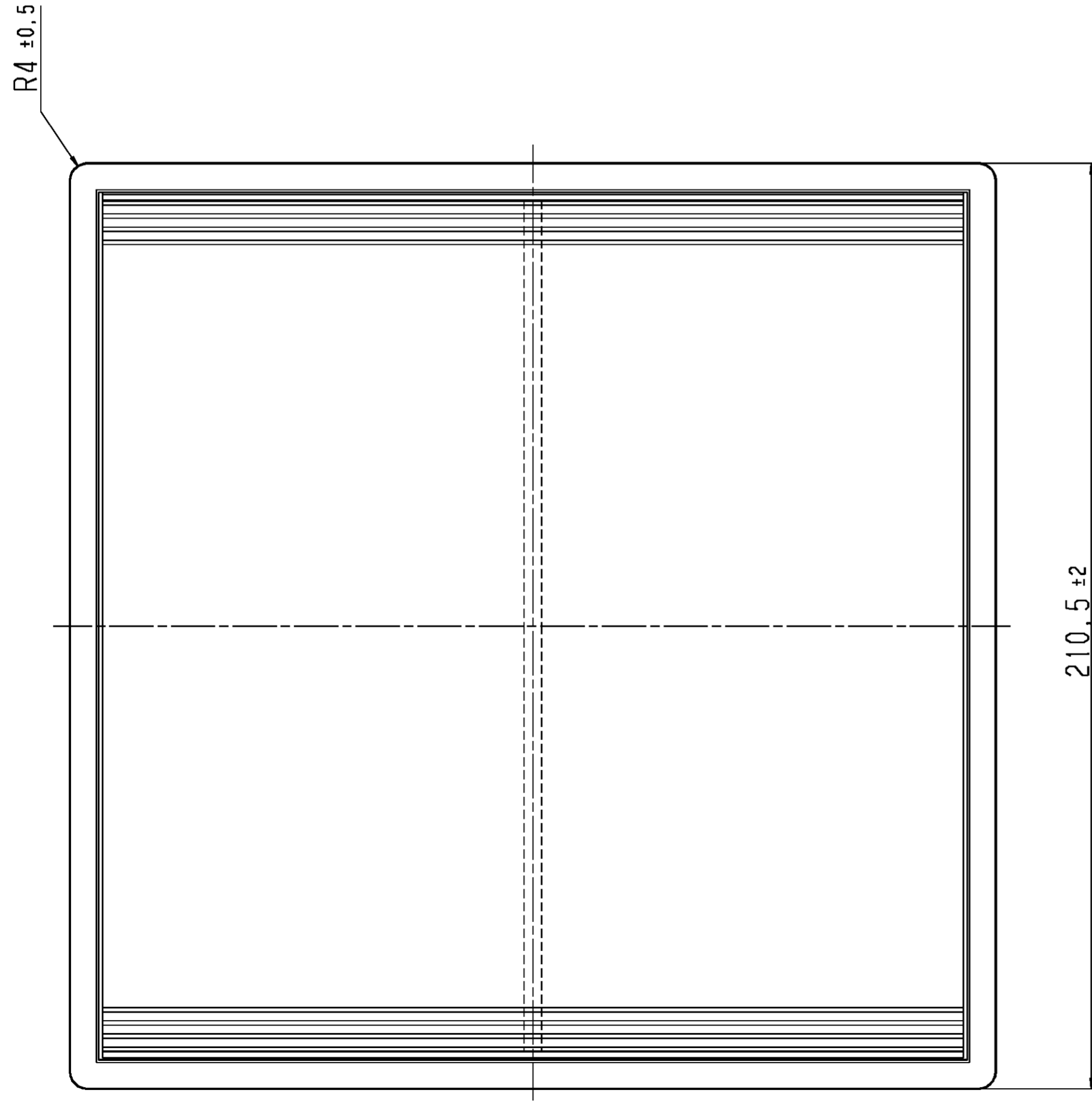

210.5 ± 2

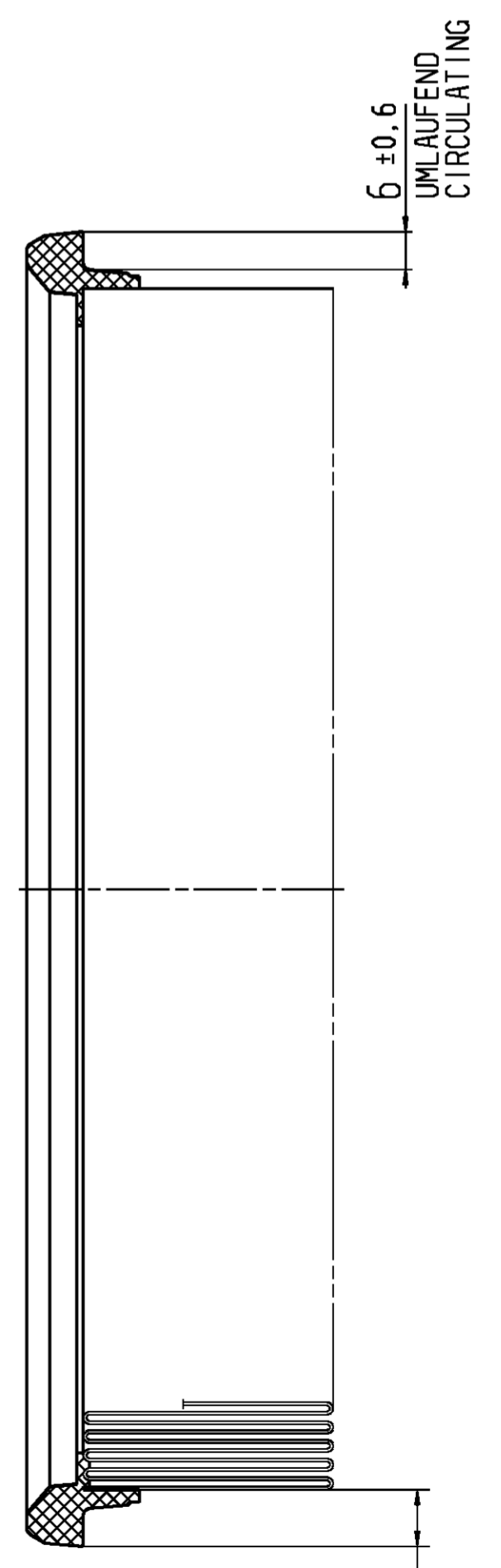

9.1 ± 1.2

6 ± 0.6
UMLAUFEND
CIRCULATING

FORM- UND LAGETOLERANZEN TOLERANCES OF FORM AND POSITION	
NACH/ ACCORDING TO ISO 1101	
OBERFLÄCHEN / SURFACES	
NACH/ ACCORDING TO ISO 1302	
WERKSTÜCKKANTEN WORKPIECE EDGES	
NACH/ ACCORDING TO DIN 6784	
MASSE OHNE TOLERANZANGABEN: DIM. WITHOUT TOLERANCES:	
LAENGEN LENGTHS	± 0.5
RÄDII RADII	± ---
FASEN CHAMFERS	± ---
WINKEL ANGLE	± ---
PROGRAMM-NR. / PROGRAM-NO.	
CAD-ZEICHNUNG CAD-DRAWING	
POS. POS.	BENENNUNG NAME
	ERSATZTEILLISTE / SPARE PARTS LIST
	BESTELL-NR. PART-NO.
	FREMD-NR. CUSTOMER-NO.